

# **COUPLING FLIGHT CONTROL SYSTEM DYNAMICS WITH AEROELASTIC EQUATIONS OF MSC/NASTRAN**

**By**

**<sup>1</sup>YAN MURSAL (E-mail: mursal@iptn.co.id)**

**<sup>2</sup>PIPIT PUSPITASARI**

**<sup>3</sup>NINEU DISYANI**

## **ABSTRACT**

This paper presents development of a procedure to include flight control system dynamics with aeroelasticity in MSC/NASTRAN. The specific application is on flutter analysis of a twin engine propeller aircraft with the yaw damper flight control system ON. The flutter analysis is performed using the PK-method.

The yaw damper transfer functions are introduced into the aeroelastic equations of motion through a combination of EPOINT and TF entries. One of the extra-points represents the rudder deflection resulting from the yaw damper system. The additional generalized unsteady-aerodynamic forces due to this extra-point are provided with down-washes supplied on DMI entries in the Bulk Data.

The analysis results are presented on V-G and V-F diagrams for two configurations, nominal and yaw damper ON.

---

<sup>1</sup> Structural Dynamics Engineer, Structural Dynamics & Flutter Dept., Aircraft Design Div., PT. IPTN

<sup>2</sup> Aeroelastic Engineer, Structural Dynamics & Flutter Dept., Aircraft Design Div., PT. IPTN

<sup>3</sup> Aeroelastic Engineer, Structural Dynamics & Flutter Dept., Aircraft Design Div., PT. IPTN

## I. Introduction

The N250 A/C has a yaw damper flight control system installed. This flight control system was designed to fulfill stability and control requirements. A yaw damper generally is added to an airplane to improve the damping ratio of the Dutch roll mode<sup>[1]</sup> (see Figure 1).

This paper presents a flutter analysis with the influence of the yaw damper on the aeroelastic system. Of course, hundreds of cases of flutter analysis have been done on this aircraft including all the flight control systems. In the initial analyses the flight control system was modeled with a linear spring and damper system. This analysis is sufficient as long as the control surface is not actively involved in the flight mechanical control and stability system. If it is involved, the feedback of the system will introduce some more energy through the actuator and may change the flutter behavior of the A/C<sup>[2]</sup>. Therefore, the flutter equation must be extended to an aeroservoelastic equation to include this influence. A method to perform an aeroservoelastic analysis with SOL 145 PK-Method will be given in the following chapters of the paper.

This paper contains five chapters. Chapter I is the Introduction followed by Chapter II which gives the airplane equation of motion for an aeroelastic system in generalized coordinates which contains only normal modes. No active system is involved in the equation.

Chapter III is devoted to control system representation. A control system is defined by transfer function matrix  $[T(s)]$  which relates the actuator outputs (control surface rotation)  $\{\delta\}$  to sensor-input deflection and rotations  $\{y_s\}$ <sup>[3]</sup>.

Chapter IV gives the flutter equation of the aeroservoelastic system which is expressed by means of a set of structural mode shapes (eigen modes) of the aircraft and an additional rudder motion as function of the active flight control system<sup>[2][3]</sup>. This additional degree of freedom is no longer orthogonal to the structural d.o.f. (generalized coordinates). It will contribute inertial coupling terms in the generalized mass matrix of the A/C equation of motion<sup>[2][4]</sup>. In addition, this rigid control surface rotation will also result in additional induced unsteady-aerodynamic forces to the A/C<sup>[3][4]</sup>. This is an open loop equation of motion<sup>[3]</sup>.

If we combine this equation with a transfer function  $[T(s)]$ , then we will get the closed loop equation of motion of the aeroservoelastic system<sup>[3]</sup>. For this particular case  $[T(s)]$  relates the rudder rotation and the airplane yaw-rate measured by a rate-gyro. That rate-gyro is located at certain position in the fuselage, Figure 2 shows a simplified block diagram of the yaw damper system.

Chapter V is the application of the method using the transfer function as stated above. It consist of data preparation:

- number of EPOINTS' needed
- transfer funtion coefficient determination
- TF entries

Chapter VI is Summary of the results and Conclusions

## II. AEROELASTIC EQUATION OF MOTION

Given below is the aeroelastic equation of motion in MSC/NASTRAN which is the fundamental equation for flutter analysis by the PK-method in modal coordinates.

$$\left[ M_{hh} p^2 + \left( B_{hh} - \frac{1}{4k} \rho \bar{c} V Q_{hh}^I \right) p + \left( K_{hh} - \frac{1}{2} \rho V^2 Q_{hh}^R \right) \right] \{ \xi \} = 0 \quad (1)$$

where :

- $M_{hh}$  = generalized modal mass matrix
- $B_{hh}$  = generalized modal damping matrix
- $K_{hh}$  = generalized modal stiffness matrix
- $Q_{hh}^I$  = generalized modal aerodynamic damping matrix of the lifting surfaces, function of reduced frequency, k and Mach number, M
- $Q_{hh}^R$  = generalized modal aerodynamic stiffness matrix of the lifting surfaces, function of reduced frequency, k and Mach number, M
- $\rho$  = density
- $V$  = velocity
- $\bar{c}$  = reference chord
- $k$  = reduced frequency =  $\omega \bar{c} / 2V$
- $\{ \xi \}$  = modal amplitude vector

## III. Control system transfer function

The Control system is defined by the transfer function matrix  $[T(s)]$  which relates actuator outputs  $\{\delta(s)\}$  to sensor input deflections and rotations  $\{Y(s)\}$ <sup>[3]</sup>.

In our case it is the airplane yaw-rate  $\{\dot{\Psi}(s)\}$ .

$$\{\delta(s)\} = [T(s)]\{Y(s)\} \dots\dots\dots(2)$$

$[T(s)]$  is (see Figure 1): - sensor dynamics  
 - electronic control system and actuator dynamics

Sensor input are extracted from vibration modes:

$$\{Y(s)\} = [\Phi_y]\{\zeta(s)\} \dots\dots\dots(3)$$

Substitute (3) to (2):

$$\{\delta(s)\} = [T(s)][\Phi_y]\{\zeta(s)\} \dots\dots\dots(4)$$

where,  $[\Phi_y]$  = modal deflections at the sensor location(s). For this purpose it is the rate-gyro location at the certain fuselage station in the A/C.

#### IV. Aeroelastic equation with flight control system dynamics:

The principal means by which linear control systems are treated in MSC/NASTRAN are the Extra Points and the Transfer functions. The variables that exist in control systems are assigned degrees of freedom called extra points. One of these degrees of freedom is the rudder deflection  $\delta(s)$  (see Figure 2). The vector of extra points is merged with the vector of modal (normal) coordinates  $\{\zeta\}$  in equation (1).

Therefore, equation (1) becomes:

$$\left( s^2 \begin{bmatrix} \mathbf{M}_{HH} & \mathbf{M}_{\zeta\delta} \\ \mathbf{M}_{\zeta\delta}^T & \mathbf{M}_{\delta\delta} \end{bmatrix} + s \begin{bmatrix} \mathbf{B}_{HH} & \mathbf{0} \\ \mathbf{0} & \mathbf{0} \end{bmatrix} + \begin{bmatrix} \mathbf{K}_{HH} & \mathbf{0} \\ \mathbf{0} & \mathbf{0} \end{bmatrix} \right) \begin{Bmatrix} \zeta(s) \\ \delta(s) \end{Bmatrix} = [\mathbf{Q}_{ms}(ik)]\{\zeta(s)\} + [\mathbf{Q}_{cs}(ik)]\{\delta(s)\} \dots\dots\dots(5)$$

where,

- $Q_{ms}$  = generalized unsteady aerodynamic coefficients matrices due to normal modes
- $Q_{cs}$  = generalized unsteady aerodynamic coefficients matrices which are a function of control surface motion due to the yaw damper.
- $\{\delta(s)\}$  = control system variables including control surface deflections (actuator outputs).
- $M_{\zeta\delta}^T, M_{\delta\zeta}$  = inertial coupling terms between control surface rotational and main surface modes which is temporarily neglected for the moment.

Equation (4) and (5) are a set of simultaneous differential equation of an aero servoelastic system. This is a closed loop aeroelastic equation of motion for a combined structure and yaw damper flight control system without any external input ( $R(s)=0$ , see Figure 2). The coefficients of  $\delta(s)$  and  $\zeta(s)$  of the flight control system transfer function (equation 4) will be put on the corresponding row and column of mass, damping and stiffness matrices of equation 5.

In MSC/NASTRAN, a TF card entry is used to put those transfer function coefficients into the right rows and columns. As an alternative, those coefficients could be put also into the matrices through DMIG entry.

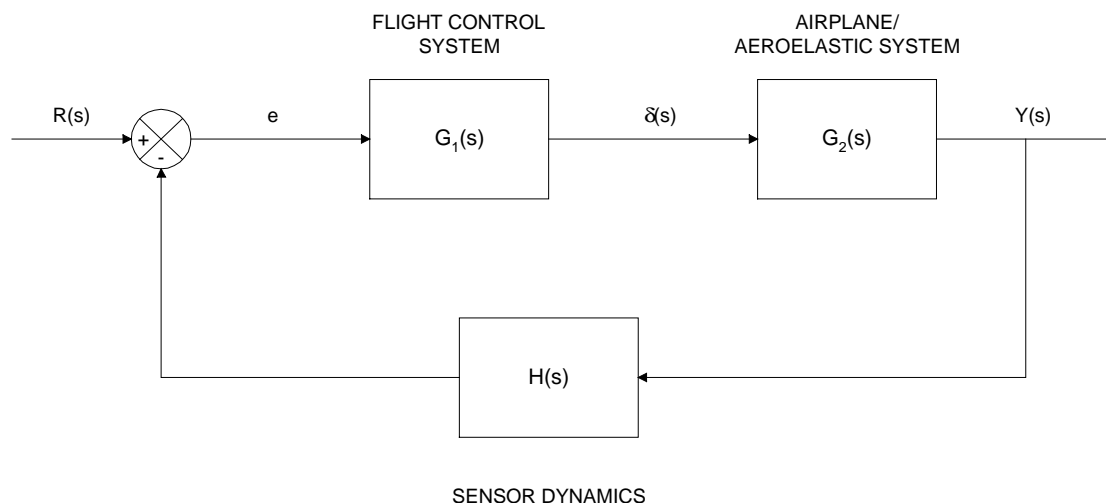

Figure 1 Combined Aeroelastic and Yaw Damper System, Block Diagram

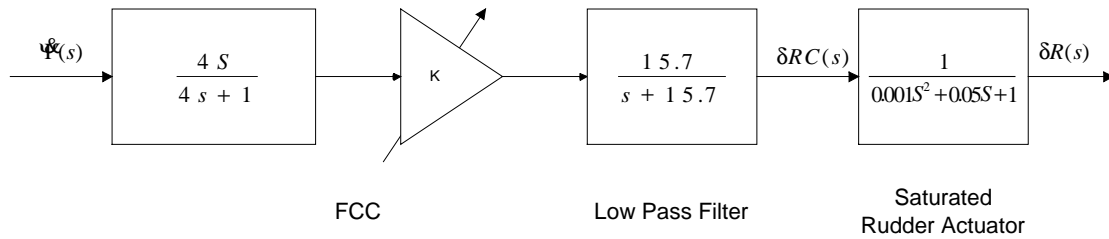

Figure 2 Yaw-Damper System, Block Diagram

## V. Introducing the Yaw Damper transfer function into MSC/NASTRAN model

The application of the above procedures is in the following example. The objective is to analyze the influence of the yaw-damper dynamics on the flutter characteristics of the airplane (see Figure 2).

This problem will be solved using SOL 145 and PK method is used for flutter solution. To add a row in the matrices, EPOINT entry should be used. In this particular example, 2 EPOINT entries are necessary. The first EPOINT 999991 is an additional generalized coordinate to simulate the output terminal of combined FCC (Flight.Control Computer) and rudder fly-by-wire ECU. In MSC/NASTRAN, the maximum order of the polynomial is 2 (two). Therefore, we could not multiply the transfer function of the combined FCC+rudder fly-by-wire ECU with the actuator transfer function. Then we need an extra EPOINT, which is EPOINT 999991. The second EPOINT 999999 entry is for simulating the rudder deflection.

From combined FCC+rudder fly-by-wire (see Figure 2):

$$G_t(s) = \frac{62.8 \cdot 1 \cdot K \cdot s}{(4s+1)(s+15.7)} = \frac{\delta_{rc}(s)}{\dot{\psi}(s)} = \frac{\delta_{rc}(s)}{[\Phi]_{1010} * \xi(s)} = \frac{\delta_{rc}(s)}{[\Phi]_{1010} * s \xi(s)} \dots \dots \dots (7)$$

where  $\dot{\psi}$  = yaw-rate measured by the rate gyro located at GRID 1010 on the fuselage  
 $[\Phi]_{1010}$  = modal deflections at GRID 1010  
 $\xi$  = normal coordinates

From the rudder actuator transfer function:

$$\delta_R(s) = H_{act}(s) * \delta_{rc}(s)$$

$$\delta_R(s) = \frac{1}{.001s^2 + .05s + 1.} * \delta_{rc}(s) \dots\dots\dots(8)$$

The TF bulk data entries are as follows:

- Combined FCC+rudder fly-by-wire :

TF	ID	999991	0	15.7	63.8	4.0			
+TF	1010	6	0.0	0.0	-11.932				

- Rudder actuator:

TF	ID	999999	0	1.0	0.05	0.001			
+TF	999991	0	-1.0	0.0	0.0				

The generalized mass, stiffness and damping matrices (Equation 6) will look like (temporarily ignore the inertial coupling terms):

$$\left[ \begin{array}{c|cc} \text{MHH} & \{0.\} & \{0.\} \\ \hline -11.932[\Phi]_{1010} & 4.0 & 0.0 \\ \hline [0.0] & 0.0 & .001 \end{array} \right] \left\{ \begin{array}{c} \xi \\ \delta_{rc} \\ \delta_r \end{array} \right\}$$

$$\left[ \begin{array}{c|cc} \text{BHH} & \{0.\} & \{0.\} \\ \hline [0.0] & 63.8 & 0.0 \\ \hline [0.0] & 0.0 & 0.05 \end{array} \right] \left\{ \begin{array}{c} \xi \\ \delta_{rc} \\ \delta_r \end{array} \right\}$$

$$\left[ \begin{array}{c|cc} \text{KHH} & \{0.\} & \{0.\} \\ \hline [0.0] & 15.7 & 0.0 \\ \hline [0.0] & -1.0 & 1.0 \end{array} \right] \left\{ \begin{array}{c} \xi \\ \delta_{rc} \\ \delta_r \end{array} \right\}$$

## **VI. Summary of the Results and Conclusions**

A procedure has been developed to include the flight control system dynamics into airplane structural dynamic model in MSC/NASTRAN Flutter solution with PK-Method.

For an Illustration of the application of the procedure, Figure 3 and Figure 4 shows results of airplane without and with yaw damper ON, respectively. Of course, we could not take final conclusion of the effect of yaw damper on the aeroelastic system only from these two results. But nevertheless we could see the potential of the yaw damper system to change the flutter behaviour of the airplane. In Figure 4, the mode with symbol O is no longer crossing zero axis as shown in Figure 3.

Actually many of parametric studies were performed to see the influence of the yaw damper system into the flutter behaviour of the A/C. An example is a structural filter added to the system.



**FIGURE 3. AIRPLANE WITH YAW DAMPER OFF**

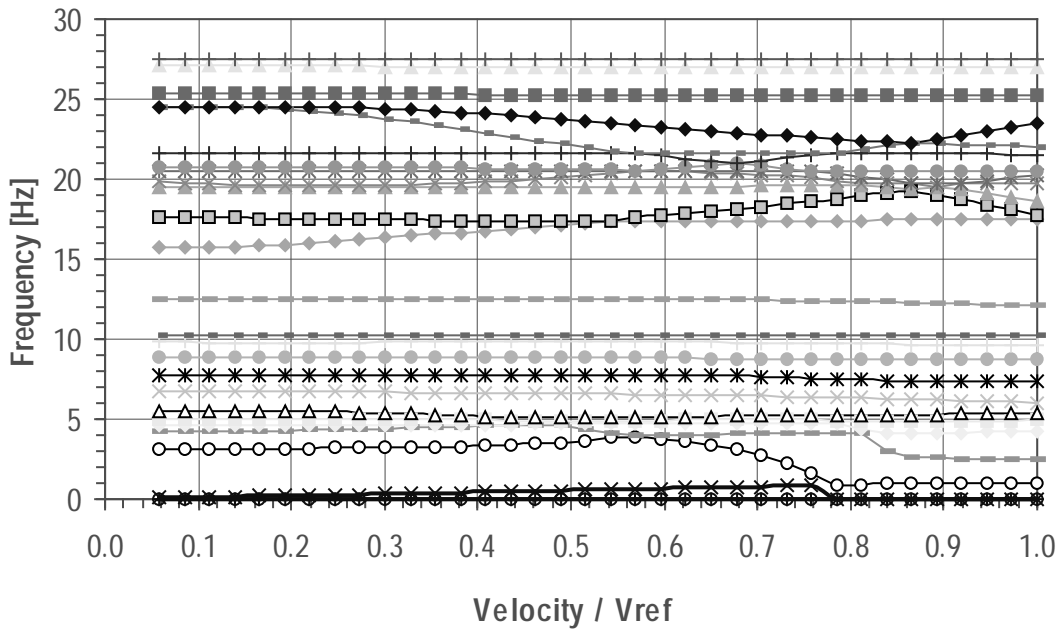
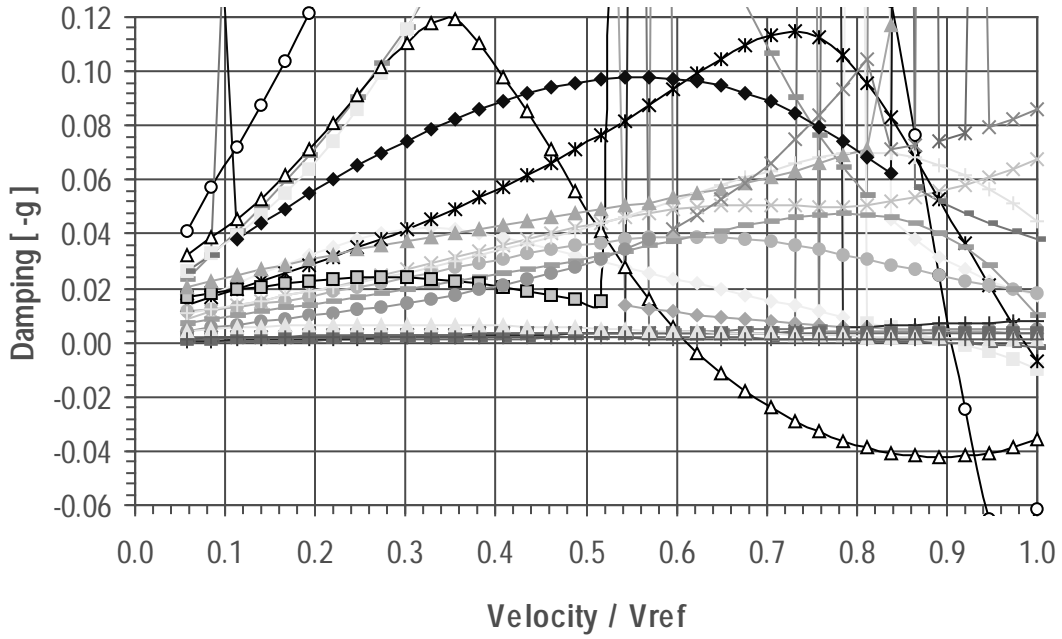

**FIGURE 4. AIRPLANE WITH YAW DAMPER ON**

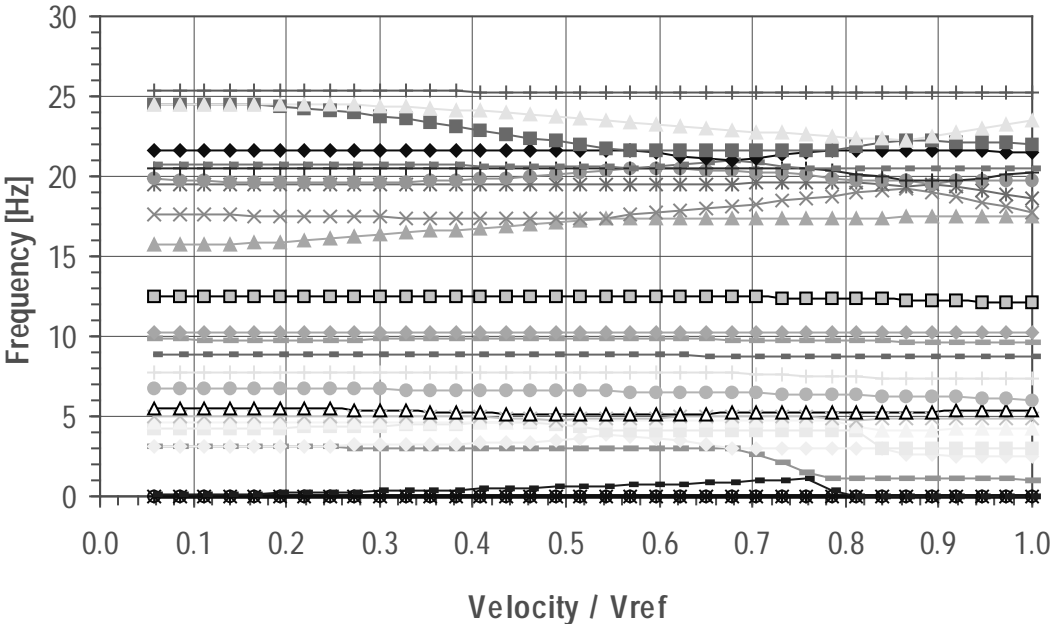
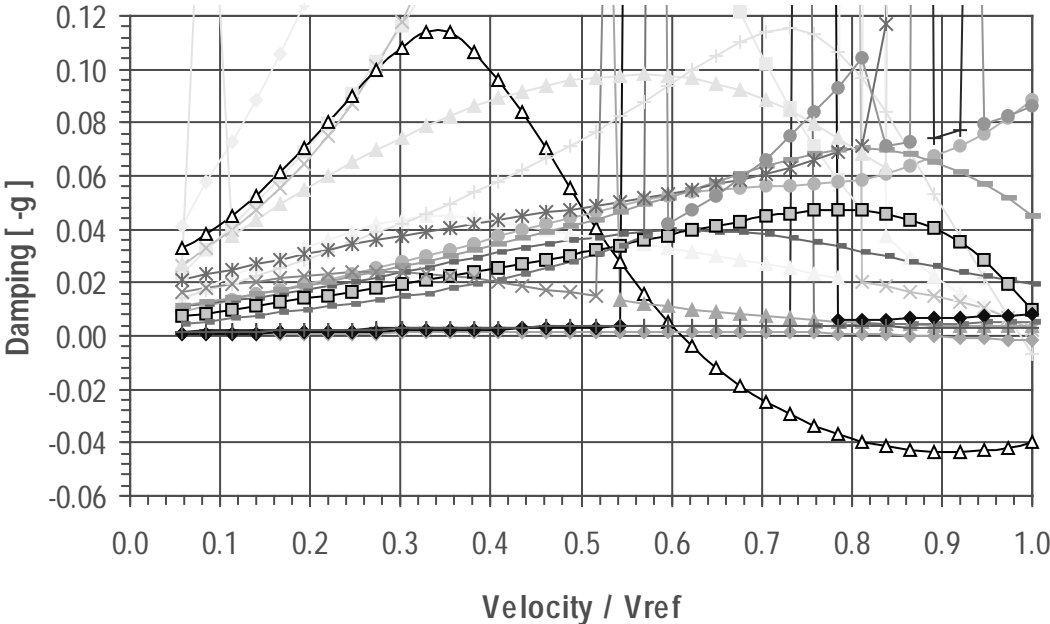

## REFERENCES

1. Roskam, J., "AIRPLANE FLIGHT DYNAMICS AND AUTOMATIC FLIGHT CONTROLS", The University of Kansas, Lawrence, Kansas, Part II, 1979.
2. Zimmermann, H., "AEROSERVOELASTICITY", Computer Methods in Applied Mechanics and Engineering 90 (1991) 719-735.
3. Karpel, M., "a course on ADVANCED AEROELASTICITY", given at Royal Melbourne Institute of Technology, Department of Aerospace Engineering Melbourne, Australia, September 21-24, 1992.
4. Rodden, W., P., "MSC/NASTRAN AEROELASTIC ANALYSIS - USER'S GUIDE ", The Macneal-Schwendler Corporation, USA, 1994.