

NACA TN 3353

# NATIONAL ADVISORY COMMITTEE FOR AERONAUTICS

TECHNICAL NOTE 3353

EFFECTIVE MOMENT OF INERTIA OF FLUID IN OFFSET, INCLINED,  
AND SWEEP-WING TANKS UNDERGOING PITCHING OSCILLATIONS

By James R. Reese and John L. Sewall

Langley Aeronautical Laboratory  
Langley Field, Va.



Washington

January 1955



TECHNICAL NOTE 3353

EFFECTIVE MOMENT OF INERTIA OF FLUID IN OFFSET, INCLINED,  
AND SWEEP-WING TANKS UNDERGOING PITCHING OSCILLATIONS

By James R. Reese and John L. Sewall

SUMMARY

Fluid-dynamics studies were made of simplified model fuel tanks mounted on a mechanism that simulated a wing undergoing torsional oscillations of a few degrees. The tanks were mounted as follows: vertically offset (pylon mounted) below the axis of oscillation; inclined to the horizontal as in a climbing or diving attitude; and swept with respect to the axis of oscillation as in a centrally mounted tank on a swept wing undergoing torsional oscillations. The effective moment of inertia of the fluid was determined experimentally for the various tank configurations over a tank-fullness range from empty to full and was essentially unaffected by the oscillation frequency of the spring-inertia dynamic system except when this frequency was near the lowest natural fluid frequency because of its own wave motion. Comparisons of the experimental and theoretical inertia solutions for full pylon-mounted tanks and centrally mounted swept-wing tanks showed good agreement. Moreover, the theoretical solutions for full centrally mounted swept-wing tanks offer good engineering approximations for partially full conditions because of the small effect of tank fullness on the ratio of the measured effective moment of inertia of the fluid to the moment of inertia of the fluid considered as a solid. For partially full pylon-mounted tanks, the ratio of the effective moment of inertia of the fluid to the moment of inertia of the solid was small, and this inertia ratio increased rapidly with tank fullness greater than 75 percent and approached the theoretical values for the 100-percent-full tank.

Studies of the effect of vertical, horizontal, and diffused baffles in a pylon-mounted tank revealed that the effective moment of inertia of the fluid was increased above that found in the unbaffled partially full tank. It was also found that the diffused baffle distributed throughout the interior of the pylon-mounted tanks produced high damping characteristics for partially full conditions, whereas the use of the diffused baffle in a partially full, centrally mounted tank did not produce high damping characteristics.

## INTRODUCTION

For airplanes in which the mass of fuel carried in either internal or external wing tanks is a large proportion of the total mass of the wing, the complicated motion of the fuel within the tanks may cause important dynamic effects that are of concern in flutter and in airplane stability. In a flutter analysis, for example, it is generally recognized that there may be a large error in the predicted flutter speed if a large quantity of fuel in the tank is assumed to behave as a solid mass. It is therefore necessary to know the effective values for the inertial and damping properties of the fuel because of its complicated motion relative to the tank boundaries.

Recent investigations of the effective values of the inertial and damping properties of the fluid simulating fuel are reported in references 1 and 2. Reference 1 is a study of the damping and effective weight of the fluid in various tanks undergoing vertical translation after instantaneous release. Reference 2 investigates the case of centrally mounted tanks in a horizontal flight attitude which are undergoing pitching oscillations. The present investigation extends the work of reference 2 to include studies involving pitching oscillations of tanks oriented as follows: vertically offset (pylon mounted) below the axis of oscillation; inclined to the horizontal as in a climbing or diving attitude; and swept with respect to the axis of oscillation as in a centrally mounted tank on a swept wing undergoing torsional oscillations of a few degrees. Studies were also made of the damping characteristics of fluids on the spring-inertia systems of oscillation in the tanks in which the baffles were distributed or diffused throughout the tank interior.

## SYMBOLS

b	half width of tank, in.
d	tank offset distance measured from center of gravity, in.
g	acceleration due to gravity, in./sec <sup>2</sup>
$g_{\alpha}$	damping factor based on logarithmic decrement for equivalent viscous damping
h	half height of tank, in.
$h_F$	mean height of free surface of fluid above tank bottom, in.

$I_F$	effective pitching moment of inertia of fluid, in-lb/sec <sup>2</sup>
$I_S$	pitching moment of inertia of fluid considered as a solid, in-lb/sec <sup>2</sup>
$i$	axis of rotation for inclined tanks
$J$	torsional rigidity for solid section normal to axis of rotation, in. <sup>4</sup>
$l$	half length of tank, in.
$m$	mass, lb-sec <sup>2</sup> /in.
$o$	axis of rotation for offset tanks
$r$	distance from axis of rotation to center of gravity of fluid, in.
$s$	axis of rotation for swept-wing tanks
$x$	longitudinal axis of tank
$y$	lateral axis of tank
$\alpha$	angle of attack, deg
$\Lambda$	angle of sweep, deg
$\rho$	mass density, lb-sec <sup>2</sup> /in. <sup>4</sup>
$\omega$	angular frequency of tank oscillation, radians/sec
$\omega_R$	lowest angular frequency of fluid, radians/sec
$d/h$	pylon-offset ratio
$l/h$	fineness ratio

#### GENERAL APPROACH TO PROBLEM

The motion of fluid in an oscillating tank is a complicated physical process that requires the consideration of effective or average values of mass and moment of inertia of the fluid. The investigations herein and in reference 2 found that, in most cases, the moment of inertia of the fluid in a tank is less than the moment of inertia of a solid body having the same mass and occupying the same volume as the fluid at rest. Thus, the fluid during oscillation is said to have an effective moment of

inertia. This effective moment of inertia was determined for a given tank fullness from a knowledge of the torsional stiffness and the measured angular frequencies of a simple spring-inertia system.

The spring-inertia systems illustrated in figure 1 were oscillated by means of a step release from the initial angular displacement. As noted earlier, the effective moments of inertia of the fluid were obtained from a knowledge of the torsional stiffness and natural torsional frequency of the system. A measure of the fluid damping behavior, according to the concept of equivalent viscous damping, is provided by the damping factor  $\zeta_\alpha$  which was determined from the logarithmic decrement of the rate of decay of the oscillations following the step release.

### MODELS AND APPARATUS

The geometric characteristics of the simplified tanks used in this investigation and the essential features of the apparatus are shown in figure 1. As can be seen, the apparatus consisted of simple spring-inertia systems in which the various tank configurations were oscillated about an axis through the center of the torsion spring. The torsion-spring restraint was a steel rod. A range of frequency was obtained by using any one of a series of rods having different degrees of stiffness. Water was chosen as the test fluid because its density was reasonably close to that of most fuels used in current aircraft and because the effects of fluid viscosity have been shown to be negligible (see refs. 1 and 2).

#### Pylon-Mounted Tanks

The tanks used to study the effect of pylon offset are designated as rectangular tanks A, B, C, and D with fineness ratios of 1, 2, 3.5, and 6, respectively (fig. 1(a)); cylindrical tank E with fineness ratio of 1.5 (fig. 1(b)); tank F, a 1/2.8-scale model of tank E; and cylindrical tank G with a fineness ratio of 6 (15 inches long and 2.5 inches in diameter). The tanks were mounted as shown in figure 1(c). The various pylon-offset ratios  $d/h$  varied from 0 to 4.00. Tank A was used to study the conditions of fluid resonance.

The effect of vertical, horizontal, and diffused baffles on the inertia ratio  $I_F/I_S$  was investigated with tank E. The locations of the circular vertical baffle and the rectangular horizontal baffle are indicated by the dotted lines in figure 1(b). Both the vertical and the horizontal baffles had no openings except for the slight clearances between the tank walls and the baffles to permit the passage of fluid.

The diffused baffle, which consisted of rubberized hair commonly used in upholstery, was compressed slightly and distributed throughout the tank interior. The effect of this baffle on the torsional damping characteristics of the system was studied by using tanks E and G; the tests on tank G were made for pylon-offset ratios ranging from 0 to 3.33.

#### Centrally Mounted Tanks

In order to determine the effects of the angle of attack and angle of sweep on the effective moment of inertia of the fluid, the tanks were oriented as shown in figures 1(d) and 1(e) so that the center of the torsion spring passed through the center of the tank. Tanks B and C were inclined at angles of attack of  $0^\circ$ ,  $30^\circ$ ,  $60^\circ$ , and  $90^\circ$  to simulate tip tanks mounted on an unswept wing in various flight attitudes. Tanks C and D were used in the angle-of-sweep apparatus to simulate tip tanks mounted on  $0^\circ$ ,  $30^\circ$ ,  $45^\circ$ , and  $60^\circ$  swept wings in level flight.

#### ANALYTICAL CONSIDERATIONS

##### Effective Moments of Inertia of the Fluid for Full Tanks

The theoretical solutions for the effective moments of inertia of the liquid in full, ellipsoidal and two-dimensional rectangular tanks oscillating in pitch about the tank center of gravity have been employed in reference 2. In general, both of these solutions rest on fundamental concepts of the potential-energy theory for incompressible fluids as set forth by Lamb in reference 3, articles 110 and 131. The solution for the rectangular tank used in reference 2 is specifically based on a relation established by Miles in reference 4 between the moment of inertia of the fluid and the torsional rigidity of solid sections. This relation may be stated as

$$I_{Fy} = I_{Sy} - 2\rho bJ_y \quad (1)$$

where  $J_y$  is the torsional rigidity of the solid cross section in a plane normal to the y-axis of rotation. The form of this expression is essentially identical to that given in reference 5 on the basis of a mechanical analogy in which the fluid is replaced by a large fixed mass, and an infinite number of small undamped systems of spring mass moving parallel to the bottom of the tank in a plane normal to the y-axis or pitch axis. (Compare eq. (1) with eq. (82) of ref. 5.)

The application of equation (1) to cases in which the axis of rotation is not a principal axis of the tank may be justified by the validity of superposition as stated in both articles 110 and 131 of reference 3. For the rotation axis vertically offset from the tank center of gravity (see fig. 1(c) for a pylon-mounted fuel tank), equation (1) becomes

$$I_{F_o} = I_{S_y} + mr^2 - 2\rho bJ_y$$

or

$$\frac{I_{F_o}}{I_{S_o}} = 1 - \frac{2\rho bJ_y}{I_{S_y} + mr^2}$$

} (2)

where the subscript *o* denotes the offset axis of rotation. Figure 2 presents a plot of this equation as applied to a rectangular tank of length  $2l$ , depth  $2h$ , and width  $2b$  for a range of fineness ratio  $l/h$  and various pylon-offset ratios  $d/h$ .

The effective moment of inertia of the fluid in full swept-wing tanks may also be calculated by applying the principle of superposition; that is, by combining the effective moments of inertia of the fluid about the principal *x*- and *y*-axes

$$I_{F_s} = I_{F_y} \cos^2\Lambda + I_{F_x} \sin^2\Lambda \quad (3)$$

where *s* is the axis of rotation for the swept-wing tank. On the basis of equation (3), equation (1) may be written for rectangular tip tanks mounted on a swept wing as

$$\frac{I_{F_s}}{I_{S_s}} = 1 - \frac{2\rho(bJ_y \cos^2\Lambda + lJ_x \sin^2\Lambda)}{I_{S_s}} \quad (4)$$

where  $J_x$  is the torsional rigidity of the rectangular cross section of the solid normal to the tank longitudinal axis, and  $I_{S_s}$  is the moment of inertia of the solid about the *s*-axis of the tank. Note that, when  $\Lambda = 90^\circ$ , the axis of rotation coincides with the *x*-axis, and the effective moment of inertia of the fluid for this particular tank corresponds to a fineness ratio given by  $b/h$ . This equation is plotted in figure 3 for angles of sweep from  $0^\circ$  to  $60^\circ$  for tanks B, C, and D.



### Fluid-Resonance Considerations

For the partially full tank, the frequency of the spring-inertia system used to determine the effective moments of inertia of the fluid was sometimes close to the frequency of some modes of oscillation of the fluid itself. In general, this fluid mode was characterized by wave motions that amounted to small disturbances of the free surface. In some cases the frequencies of oscillation were close to the lowest (or fundamental) fluid frequency, which corresponds to a large, unbroken wave motion involving nearly all the fluid. Such circumstances were identified as conditions near fluid resonance, which was established on an analytical basis by means of the following expression:

$$\omega_R = \sqrt{\frac{\pi g}{2l} \tanh \frac{\pi h_F}{2l}} \quad (5)$$

where  $\omega_R$  is the lowest angular frequency of the fluid and  $h_F$  is the mean height of the free surface of the fluid above the bottom of the tank. This frequency equation is obtained from articles 227 and 228 in reference 3 and gives the fundamental frequency for the case of surface waves in a rectangular tank in which both the vertical and the horizontal motions of the fluid are involved.

### RESULTS AND DISCUSSION

The results of this investigation are presented in tables I to VI. The inertia ratios presented in tables I, II, IV, and V are average values corresponding to the ranges of test frequency which were considerably above the lowest resonance frequencies of the fluid. The effects of vertical, horizontal, and diffused baffles on the moments of inertia of the fluid appear in table II. Table III shows the effects of frequency near fluid resonance. Tables IV and V give the values of  $I_F/I_S$  obtained for centrally mounted swept-wing tanks at angles of sweep and angles of attack, respectively. The damping factors for tank E are given in tables I and II, and the damping factors for tank G are given in table VI. The values of these damping factors are given as ranges wherever more than one interpretation of the trends in the decaying oscillation is possible.

#### Effect of Frequency

The present investigation covered a wider range of frequency than that of reference 2 by extending into the region of fluid resonance. The frequency range for tank A extended into this region, and an indication of the influence of frequency on the effective moment of inertia

of the fluid for this tank may be seen in figure 4. The inertia ratios listed in table III are shown as functions of the frequency ratio based on the calculated fundamental frequency of the fluid given by equation (5). The large decreases in  $I_F/I_S$  for low values of  $\omega/\omega_R$  are attributed to the nearness to fluid resonance. In cases where the angular frequency of the spring-inertia system was close to the lowest angular fluid-resonance frequency,  $\omega_R$  could be determined experimentally by oscillating the system at constant amplitude, the energy being supplied manually. An experimental value for  $\omega_R$  obtained in this manner for tank A, 75 percent full, is given in table III. For all other tank configurations studied, variations in frequency over a wide range did not appreciably influence the effective moment of inertia of the fluid because the values of  $\omega/\omega_R$  were generally greater than 3. It may be of interest to note that the frequency ratios below this value are generally of concern in problems of rigid-body stability.

#### Pylon-Mounted Tanks

As previously noted, inertia ratios computed by means of equation (2) for full pylon-mounted tanks are shown in figure 2 for a number of pylon-offset ratios and a wide range of fineness ratio. The following observations may be made from these curves: For low fineness ratios and very small pylon-offset ratios, the effective moment of inertia of the fluid is low as compared with the moment of inertia of the solid; however, as the pylon-offset ratio becomes larger, the inertia ratio approaches unity. Furthermore, as the fineness ratio increases, the inertia ratios also approach unity and are not strongly affected by the pylon-offset ratio; the effect is indicated by the convergence of the curves. Several experimental points for the tanks investigated are shown in figure 2 for a pylon-offset ratio of 2.36. It can be seen that there is excellent agreement of experimental data with theory for tanks B and C and acceptable agreement for tanks A and D. Experimental points are also shown for a pylon-offset ratio  $d/h = 0$  and serve to supplement the good correlation of experiment with theory shown for the centrally mounted case in reference 2.

Effect of tank fullness.- Some typical experimental results for partially full pylon-mounted tanks are shown in figure 5 in which the ratio of fluid inertia to solid inertia is shown as a function of tank fullness. For the range of tank fullness from 25 to 75 percent full, the inertia ratio was low and increased rapidly as the ratio approached the theoretical value for the full-tank condition. These results indicate that the usual application of the principle of superposition to calculate  $I_{F_0}$  by means of a relation such as

$$I_{F_0} = I_{F_y} + mr^2 \quad (6)$$

for partially full tanks would give erroneous answers. That is, there is a large loss of effectiveness in the fluid as compared with moment of inertia of the solid, and this loss may be primarily in the transfer term  $mr^2$ ; if this is true, some effective mass would have to be used. The large increase in inertia ratio for conditions approaching 100 percent full is attributed to the restrictions imposed by the tank boundary on the motion of the free fluid surface. For fineness ratios equal to or greater than 2 and for tanks 25 to 75 percent full, it should also be noted that the inertia ratio remained essentially constant for a given fineness ratio and increased with increasing fineness ratio for a given tank fullness.

Effect of pylon offset.- The effect of pylon offset on the inertia ratio is presented in figure 6. The data for pylon offsets of 2.36 and 3.33 are shown as solid and dashed curves, respectively. As can be seen, the inertia ratio appears to decrease with increasing pylon-offset ratio for partially full tanks. Moreover, this effect appears to be independent of the fineness ratio which is indicated by the fact that the percentage decrease-in-inertia ratio due to the increase in pylon offset is about the same for both fineness ratios.

Effects of tank size and shape.- In order to determine the effect of tank size, the 1/2.8-scale model of tank E was tested over a wide range of frequency. The comparison of the results of these tests (i.e., table I for tank F) with the data obtained for tank E indicates that the effect of size on the inertia ratio may not be important for pylon-mounted tanks. A comparison of the data shown in figure 5 for the rectangular tank of fineness ratio 2 with the data shown in figure 7 for the un baffled cylindrical tank of fineness ratio 1.5 indicates that the tank shape also appears to have a minor effect on the inertia ratio for pylon-mounted tanks.

Effect of baffles.- Figure 7 shows the effect of baffles on the inertia ratio for tank E over a complete range of tank fullness. For purposes of comparison the data for the tank without baffles is also included. As may be seen, all the baffles used tended to raise the effective moment of inertia of the fluid in the partially full tank. Of the three baffle configurations studied, the vertical and horizontal baffle resulted in a large increase in the inertia ratio from 45 to 85 percent fullness, and the abrupt rise in the inertia ratio at 50 percent fullness can be attributed to the fact that the fluid level for this condition was coincident with the location of the horizontal baffle. It may be noted that the effect of baffles on the inertia ratio was found to be insignificant for the full-tank condition.

### Centrally Mounted Tanks

Effect of angle of sweep.- As previously noted, theoretical inertia ratios computed by means of equation (4) for full tip tanks mounted on a swept wing are shown in figure 3 for the rectangular tanks studied in this investigation. Experimental points for tanks C and D (fineness ratios 3.5 and 6, respectively) shown in the figure are in good agreement with the theory for angles of sweep from  $0^\circ$  to  $45^\circ$ . Moreover, as can be seen, the effect of tank fullness is small. Thus, equation (4) appears to offer a good engineering approximation of the effective moment of inertia of fluids in centrally mounted swept-wing tanks for any fullness.

When swept-wing tanks are pylon mounted, it appears that the effect of the pylon offset overshadows the effect of the angle of sweep to such a degree that the inertia ratio very closely follows the trends for offset tanks as shown in figure 5.

Effect of angle of attack.- The effect of angle of attack on the inertia ratio  $I_F/I_S$  for centrally mounted tanks is shown in figure 8. As can be seen, the overall effect of angle of attack was small. The dips in the curves, particularly for the 25-percent-full condition, may be due to the influence of the vertical component of the fluid inertia for a given angle of attack. Comparison of parts a, b, and c of figure 8 shows that the effect of tank fullness for different angles of attack appears to be small.

### Effect of Diffused Baffle on Damping Factor

While studying the effective moment of inertia of the fluid in pylon-mounted tank E equipped with the diffused baffle, an unusual case of high damping was encountered. This case was explored further by use of tank G for pylon-offset ratios of  $d/h = 0, 2.36, \text{ and } 3.33$ , and the results are shown in figure 9 in terms of the damping factor  $g_\alpha$  as a function of tank fullness. The curves were obtained from decaying oscillations resulting from a step release at approximately the same initial amplitude in each case, and this amplitude was high enough to cause sloshing in the un baffled, centrally mounted tank. Each elongated data point indicates the range of values of  $g_\alpha$  given in table VI for a particular condition of tank fullness and pylon offset.

As can be seen, the damping due to the diffused baffle was greatly increased in the partially full tank as the pylon-offset ratio was increased. The maximum damping occurred for the approximately 75-percent-full condition for pylon-offset ratios greater than  $d/h = 0$ . (See figs. 9(a) and (b); the large increase in  $g_\alpha$  for  $d/h = 3.33$  in fig. 9(a) is similar to that found for tank E at  $d/h = 2.86$ , table II.)

For the partially full, centrally mounted tank ( $d/h = 0$ ), the diffused baffle had the effect of sharply reducing the damping as figure 9(c) clearly shows. However, as was pointed out in reference 2, the damping of the fluid in un baffled, centrally mounted tanks increases with the amplitude of oscillation. At a lower initial amplitude, sloshing was not present in centrally mounted tank G without baffles, and the damping factor was essentially the same as that obtained with the diffused baffle. The damping factor in the tanks with the diffused baffle appeared to be independent of amplitude for all three pylon offsets. It should also be observed from these figures that, in all cases of high damping, the value of  $g_{\alpha}$  decreased rapidly as the extremes of tank fullness were approached.

A reasonable explanation for this damping behavior is offered as follows: For the pylon-mounted tank, the diffused baffle resists the forward and rearward motion of the entire fluid and produces an amount of damping that is dependent on the pylon offset. The high damping in the un baffled, centrally mounted tank results from the sloshing action of the fluid near the ends of the tank. When the diffused baffle is added, this sloshing is arrested and the damping is reduced.

The high damping characteristics of the diffused baffle suggest that this unconventional baffle might hold considerable promise for pylon-mounted tank configurations. For example, undesirable oscillations sometimes encountered in partially full pylon-mounted tanks could be heavily damped by use of a material similar to the rubberized hair used in this investigation. This material occupied only about 3.5 percent of the tank volume, and in addition, only about 3 percent of the total amount of fluid was trapped in the hair. Thus, the usable capacity of the tank was reduced by approximately 6.5 percent. In a 230-gallon tank, this percentage would amount to a fuel penalty of about 15 gallons. However, it may be possible to reduce this fuel penalty still further by using a lighter less-absorbent material.

#### CONCLUSIONS

From the results of these studies, the following conclusions appear to be valid for conditions where the angular frequency of the spring-inertia system with fluid is greater than about three times the lowest angular frequency of the fluid itself:

1. In pylon-mounted tanks for a wide range of fullness up to 75 percent, the ratio of the moment of inertia of the fluid to moment of inertia of the solid is nearly constant for fineness ratios equal to or greater than 2 and considerably lower than it is for the full-tank conditions.

The inertia ratio  $I_F/I_S$  increases rapidly for conditions from 75-percent-full to 100-percent-full tank for all fineness ratios.

2. For the offset tanks investigated, the effect of tank size and shape on the ratio of the moments of inertia of fluid to solid is small.

3. Baffles in partially full pylon-mounted tanks can cause significant increases in the ratio of moment of inertia of fluid to solid.

4. Because of its high damping characteristics, the diffused baffle distributed throughout the tank volume appears to be a promising means of damping undesirable oscillations sometimes encountered on partially full pylon-mounted tanks.

5. For the case of centrally mounted swept-wing tanks, analytical solutions for the full-tank condition offer good engineering approximations of the effective inertia ratio for any tank fullness.

Langley Aeronautical Laboratory,  
National Advisory Committee for Aeronautics,  
Langley Field, Va., October 4, 1954.

#### REFERENCES

1. Merten, Kenneth F., and Stephenson, Bertrand H.: Some Dynamic Effects of Fuel Motion in Simplified Model Tip Tanks on Suddenly Excited Bending Oscillations. NACA TN 2789, 1952.
2. Widmayer, Edward, Jr., and Reese, James R.: Moment of Inertia and Damping of Fluid in Tanks Undergoing Pitching Oscillations. NACA RM L53E01a, 1953.
3. Lamb, Horace: Hydrodynamics. Sixth ed., Cambridge Univ. Press, 1932.
4. Miles, John W.: An Analogy Among Torsional Rigidity, Rotating Fluid Inertia, and Self-Inductance for an Infinite Cylinder. Jour. Aero. Sci., vol. 13, no. 7, July 1946, pp. 377-380.
5. Graham, E. W., and Rodriguez, A. M.: The Characteristics of Fuel Motion Which Affect Airplane Dynamics. Rep. No. SM-14212, Douglas Aircraft Co., Inc., Nov. 27, 1951.

TABLE I.- DATA OBTAINED FOR PYLON-MOUNTED TANKS

Tank	Fineness ratio, l/h	Tank fullness, percent	Data for offset ratio of -								Damping factor, $\xi_a$
			2.36		3.33		4.00		2.86		
			$I_{F_0}/I_{S_0}$	Frequency range, cps	$I_{F_0}/I_{S_0}$	Frequency range, cps	$I_{F_0}/I_{S_0}$	Frequency range, cps	$I_{F_0}/I_{S_0}$	Frequency range, cps	
A	1	25	0.19	11.0 to 20.9	0.22	8.1 to 15.6	----	-----	----	-----	----
		50	.35	10.0 to 18.9	.38	7.4 to 14.1	----	-----	----	-----	----
		75	.49	9.1 to 17.1	.52	6.7 to 12.8	----	-----	----	-----	----
		100	.86	7.7 to 14.7	.90	5.6 to 10.8	----	-----	----	-----	----
B	2	25	.14	9.2 to 43.6	.09	7.3 to 34.9	----	-----	----	-----	----
		50	.15	9.0 to 42.9	.14	7.1 to 33.8	----	-----	----	-----	----
		75	.18	8.8 to 42.0	.21	6.9 to 32.4	----	-----	----	-----	----
		100	.89	7.1 to 33.4	.91	5.5 to 25.8	----	-----	----	-----	----
C	3.5	25	.23	6.3 to 29.6	.17	5.4 to 25.5	----	-----	----	-----	----
		50	.23	6.2 to 28.8	.16	5.3 to 25.0	----	-----	----	-----	----
		75	.22	6.1 to 28.2	.16	5.2 to 24.5	----	-----	----	-----	----
		100	.89	4.8 to 22.3	.89	4.0 to 18.6	----	-----	----	-----	----
D	6	25	.45	10.5 to 20.6	.33	9.5 to 18.5	----	-----	----	-----	----
		50	.44	8.9 to 19.2	.32	9.1 to 17.4	----	-----	----	-----	----
		75	.45	9.4 to 18.2	.33	8.6 to 16.7	----	-----	----	-----	----
		100	.91	7.5 to 14.6	.90	6.6 to 12.8	----	-----	----	-----	----
E	1.5	0	----	-----	----	-----	----	-----	----	-----	0.003
		25	----	-----	----	-----	0.10	8.1 to 11.6	0.12	10.8 to 15.4	.017
		50	----	-----	----	-----	.18	7.4 to 10.7	.18	10.0 to 14.3	.018
		75	----	-----	----	-----	.28	6.7 to 9.6	.27	9.1 to 12.8	.019
		100	----	-----	----	-----	.96	4.5 to 6.5	.94	6.1 to 8.6	.006
F	1.5	25	----	-----	----	-----	.13	14.0 to 36.1	.10	17.7 to 46.0	----
		50	----	-----	----	-----	.19	13.4 to 34.8	.15	17.3 to 44.7	----
		75	----	-----	----	-----	.30	12.7 to 32.5	.24	16.5 to 42.4	----
		100	----	-----	----	-----	.94	9.9 to 25.6	.91	13.1 to 33.8	----

TABLE II.- EFFECT OF BAFFLES

[Tank E;  $d/h = 2.86$ ]

Type of baffle	Tank fullness, percent	$I_{F_0}/I_{S_0}$	Frequency range, cps	Damping factor, $\xi_\alpha$
Vertical	25	0.22	5.3 to 9.9	-----
	50	.36	4.7 to 8.5	-----
	75	.53	4.1 to 7.4	-----
	100	.94	3.2 to 6.0	-----
Vertical and Horizontal	25	.22	5.0 to 9.6	-----
	40	.29	4.8 to 8.8	-----
	50	.89	3.7 to 7.2	-----
	60	.80	3.6 to 7.2	-----
	75	.67	3.7 to 6.9	-----
	90	.65	3.7 to 6.7	-----
	100	.96	3.2 to 6.0	-----
Diffused	0	---	---	0.008
	10.3	.52	5.2	.122
	25.7	.45	4.8	.235
	51.5	.42	4.4	.299
	77.2	.54	3.9	.399
	93	.70	3.6	.284
	100	.94	3.2	.017



TABLE III.- EFFECT OF FREQUENCY

[Tank A;  $d/h = 3.33$ ]

Tank fullness, percent	$I_{F_o}/I_{S_o}$	Frequency, cps	Angular frequency ratio, $\omega/\omega_R$
25	$\left\{ \begin{array}{l} 0.080 \\ .230 \\ .210 \end{array} \right.$	3.28	1.72
		8.10	4.25
		15.60	8.19
50	$\left\{ \begin{array}{l} .095 \\ .380 \\ .380 \end{array} \right.$	3.22	1.48
		7.38	3.40
		14.10	6.50
75	$\left\{ \begin{array}{l} \text{-----} \\ .195 \\ .520 \\ .510 \end{array} \right.$	<sup>a</sup> 1.98	.88
		3.11	1.39
		6.70	2.99
		12.80	5.72

<sup>a</sup>Measured at a frequency near fluid resonance.

TABLE IV.- EFFECT OF ANGLE OF SWEEP  $\Delta$  ON CENTRALLY MOUNTED TANKS

Tank	Fineness ratio, $l/h$	Tank fullness, percent	Data for angles of sweep of -							
			$0^\circ$		$30^\circ$		$45^\circ$		$60^\circ$	
			$\frac{I_{Fs}}{I_{Ss}}$	Frequency range, cps	$\frac{I_{Fs}}{I_{Ss}}$	Frequency range, cps	$\frac{I_{Fs}}{I_{Ss}}$	Frequency range, cps	$\frac{I_{Fs}}{I_{Ss}}$	Frequency range, cps
C	3.5	$\left\{ \begin{array}{l} 25 \\ 50 \\ 75 \\ 100 \end{array} \right.$	0.73	19.6 to 38.3	0.70	21.4 to 41.7	0.64	23.0 to 45.0	0.56	25.0 to 49.3
			.72	18.6 to 36.6	.68	20.5 to 40.0	.64	22.2 to 43.5	.56	24.5 to 48.3
			.68	17.9 to 35.1	.68	19.7 to 38.5	.63	21.5 to 42.2	.55	24.0 to 47.4
			.74	17.0 to 33.4	.71	18.8 to 36.6	.67	20.7 to 40.2	.61	23.3 to 45.5
D	6	$\left\{ \begin{array}{l} 25 \\ 50 \\ 75 \\ 100 \end{array} \right.$	.88	12.0 to 23.6	.84	12.6 to 24.6	.83	14.6 to 28.2	.83	17.7 to 34.3
			.88	10.8 to 21.1	.86	11.5 to 22.5	.83	13.5 to 26.1	.84	16.6 to 32.2
			.88	9.9 to 19.4	.87	10.7 to 20.9	.84	12.5 to 24.5	.85	15.7 to 30.4
			.91	9.1 to 17.8	.88	9.9 to 19.4	.88	11.7 to 22.6	.86	14.8 to 28.6

TABLE V.- EFFECT OF ANGLE OF ATTACK  $\alpha$  ON CENTRALLY MOUNTED TANKS

Tank	Fineness ratio, $l/h$	Tank fullness, percent	Data for angles of attack of -							
			$0^\circ$		$30^\circ$		$60^\circ$		$90^\circ$	
			$\frac{I_{F_i}}{I_{S_i}}$	Frequency range, cps	$\frac{I_{F_i}}{I_{S_i}}$	Frequency range, cps	$\frac{I_{F_i}}{I_{S_i}}$	Frequency range, cps	$\frac{I_{F_i}}{I_{S_i}}$	Frequency range, cps
B	2	$\left\{ \begin{array}{l} 25 \\ 50 \\ 75 \\ 100 \end{array} \right.$	0.50	18.8 to 49.1	0.34	19.1 to 50.0	0.38	19.0 to 49.5	0.33	19.0 to 49.5
			.48	18.0 to 47.5	.42	18.3 to 48.0	.51	18.2 to 47.1	.50	18.2 to 47.1
			.44	17.5 to 46.3	.50	17.5 to 45.7	.49	17.8 to 46.2	.48	18.0 to 46.2
			.46	16.7 to 43.9	.46	16.7 to 43.9	.46	16.7 to 43.9	.46	16.7 to 43.9
C	3.5	$\left\{ \begin{array}{l} 25 \\ 50 \\ 75 \end{array} \right.$	.73	19.6 to 38.3	.70	9.5 to 24.9	.68	9.4 to 24.6	.56	9.5 to 24.6
			.72	18.6 to 36.6	.75	9.0 to 23.4	.75	9.0 to 23.2	.74	9.0 to 23.2
			.68	17.9 to 35.1	.73	8.6 to 22.5	.65	8.8 to 23.0	.68	8.9 to 23.0

TABLE VI.- DAMPING FACTORS  $\xi_\alpha$  DETERMINED WITH DIFFUSED BAFFLE AND WITHOUT BAFFLES

[Tank G]

Tank fullness, percent	Damping factors $\xi_\alpha$ for offset ratios of -					
	0		2.36		3.33	
	Without baffle	With diffused baffle	Without baffle	With diffused baffle	Without baffle	With diffused baffle
0	0.009	0.011	0.013	0.011	0.012	0.009
25	.109 to .189	.027	.047 to .099	.071	.059 to .079	.101
50	.109 to .189	.027	.074 to .110	.096	.059 to .071	.164
75	.064 to .091	.027	.035 to .049	.126	.024	.203
100	.009	.019	.009	.019	.010	.017

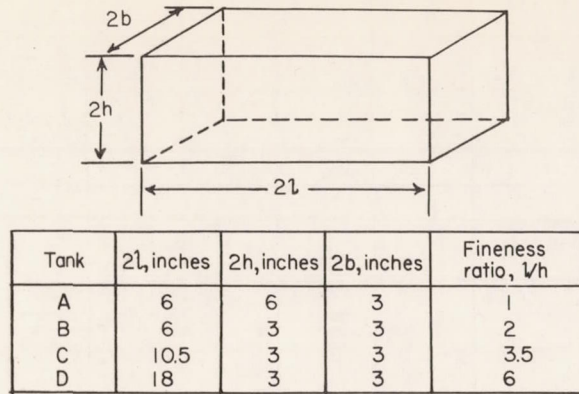

(a) Rectangular tanks.

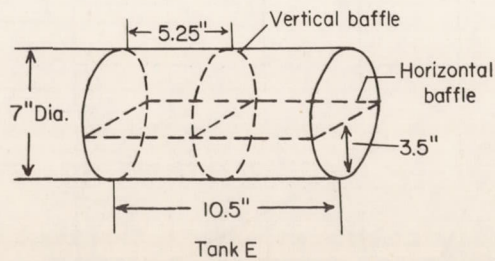

(b) Circular-cylinder tank. Fineness ratio, 1.5.

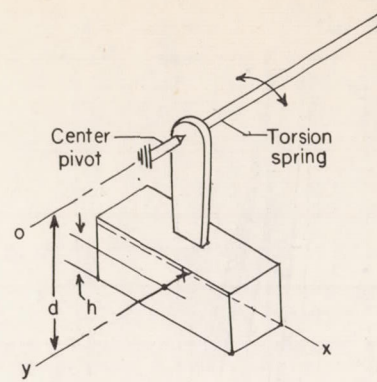

(c) Pylon-mounted tank.

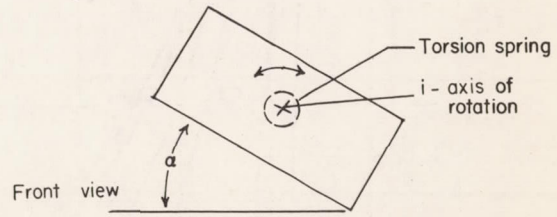

(d) Inclined tank.

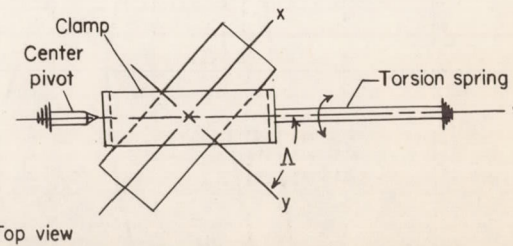

Top view

(e) Swept-wing tank.

Figure 1.- Tank shapes and dynamic systems.

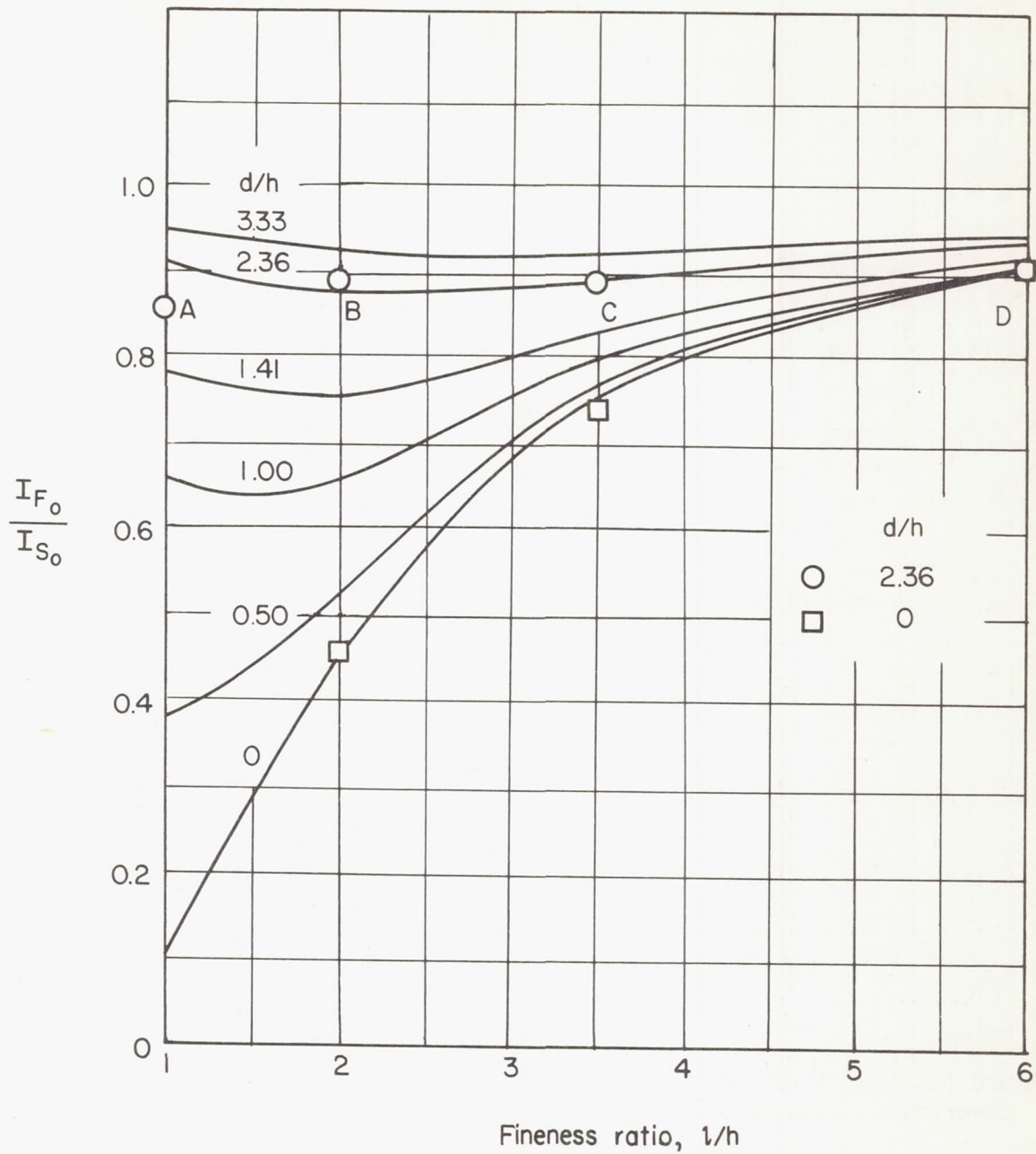

Figure 2.- Effect of fineness ratio on theoretical inertia ratios for full pylon-mounted rectangular tanks.

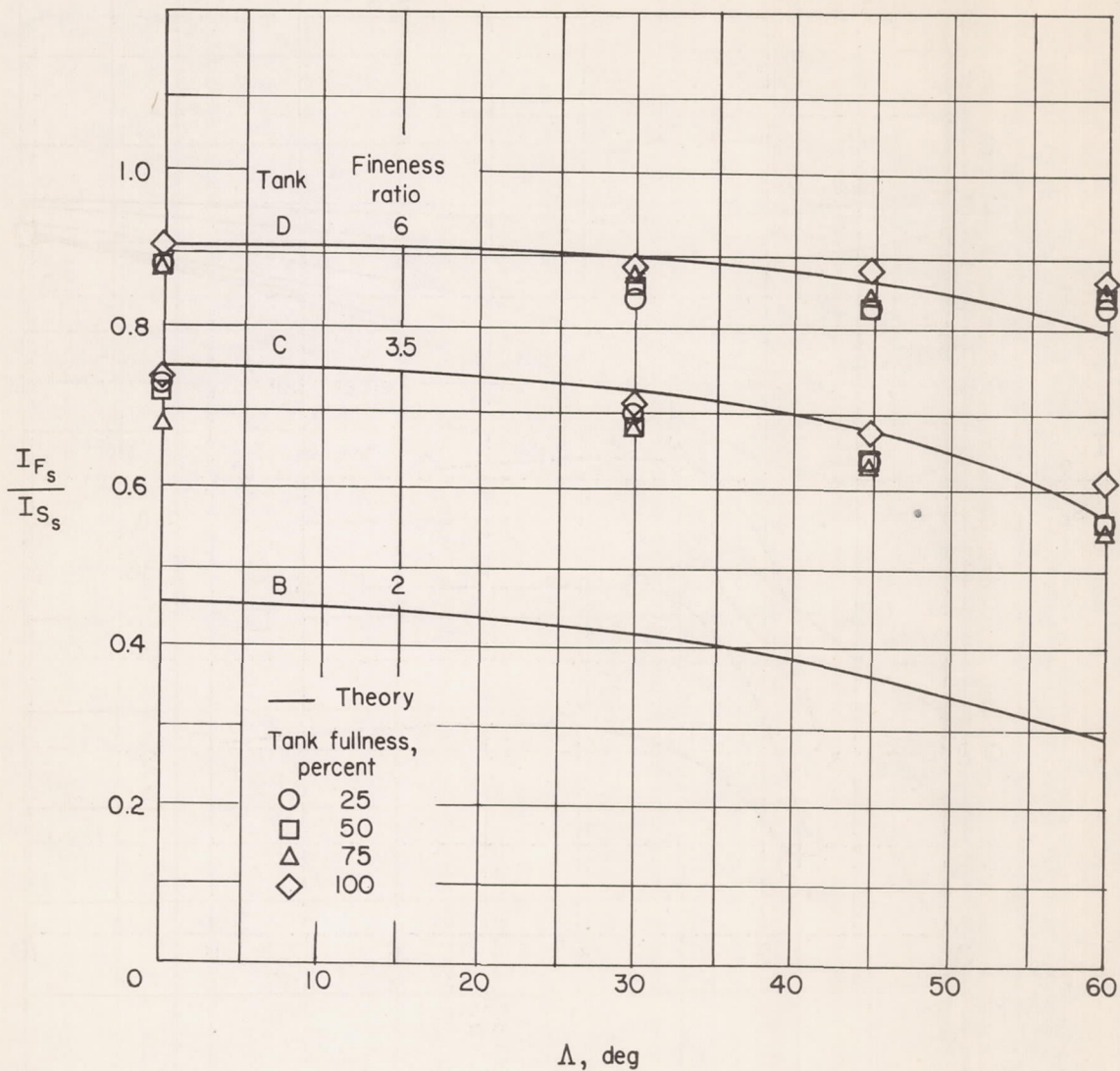

Figure 3.- Effect of sweep on inertia ratio for centrally mounted tanks. Theoretical data were calculated for tanks with 100 percent fullness.

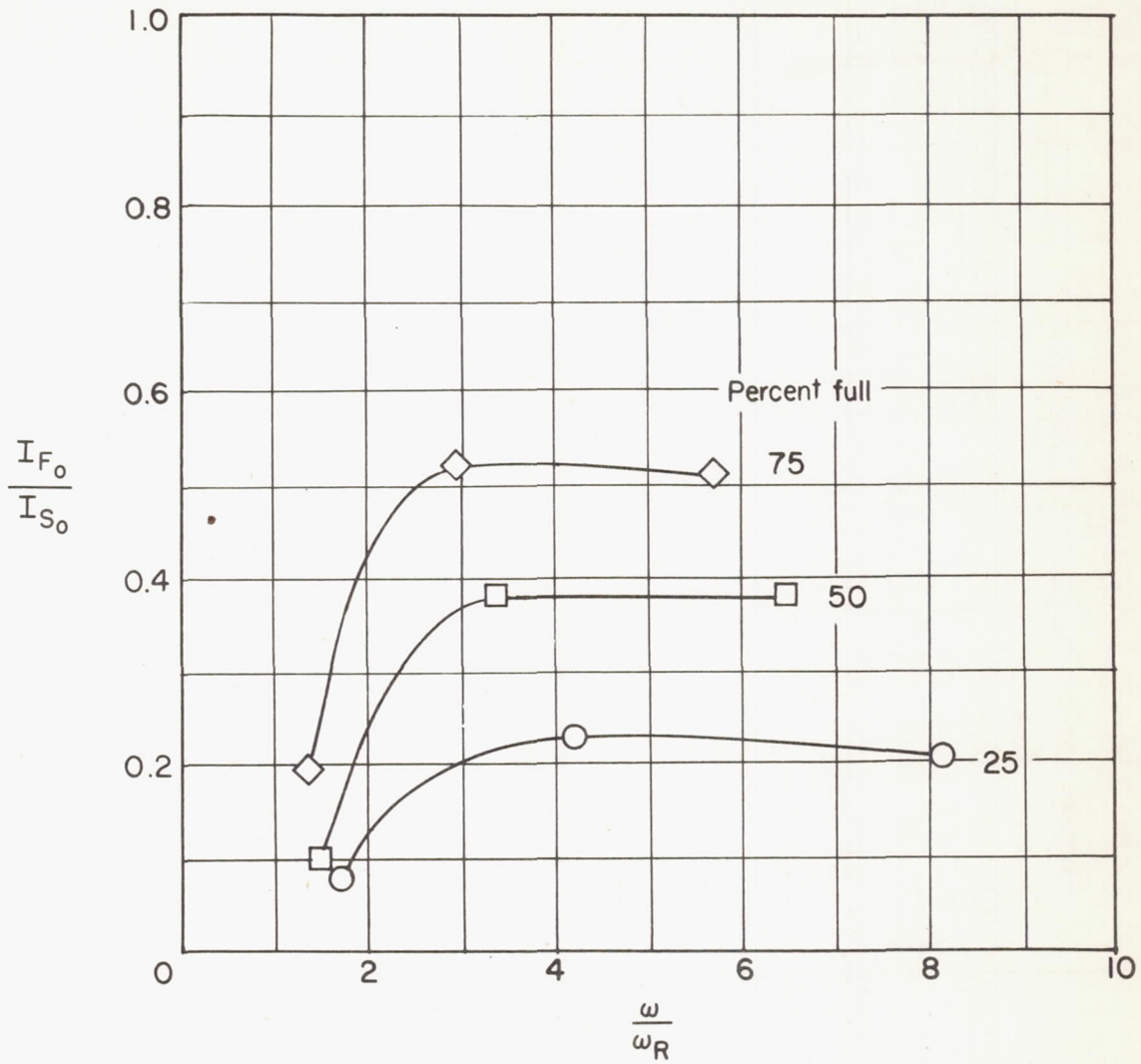

Figure 4.- Effect of frequency on inertia ratio for pylon-mounted tank A.  
 $d/h = 3.33$ .



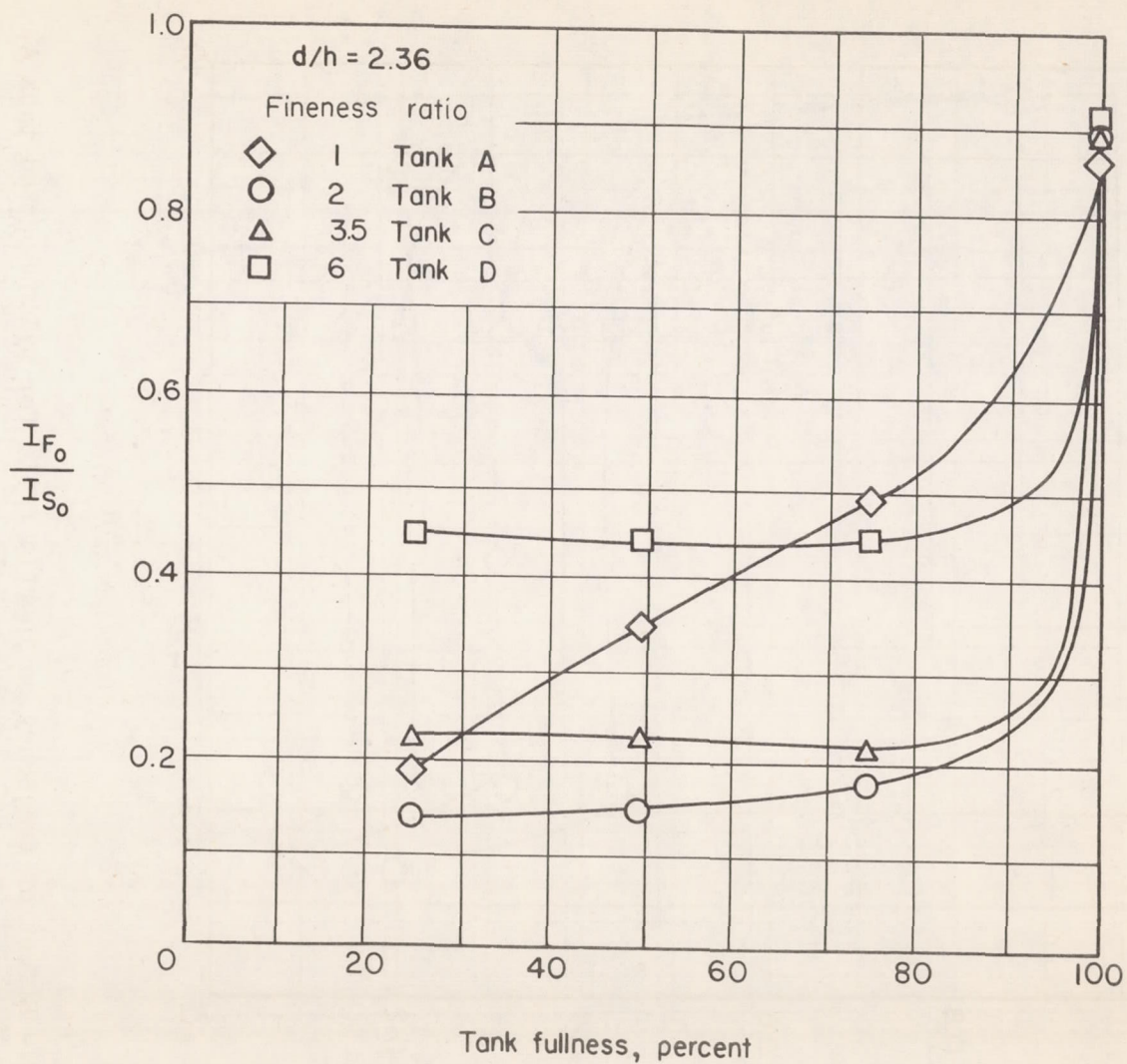

Figure 5.- Effect of tank fullness on inertia ratio for pylon-mounted tanks.

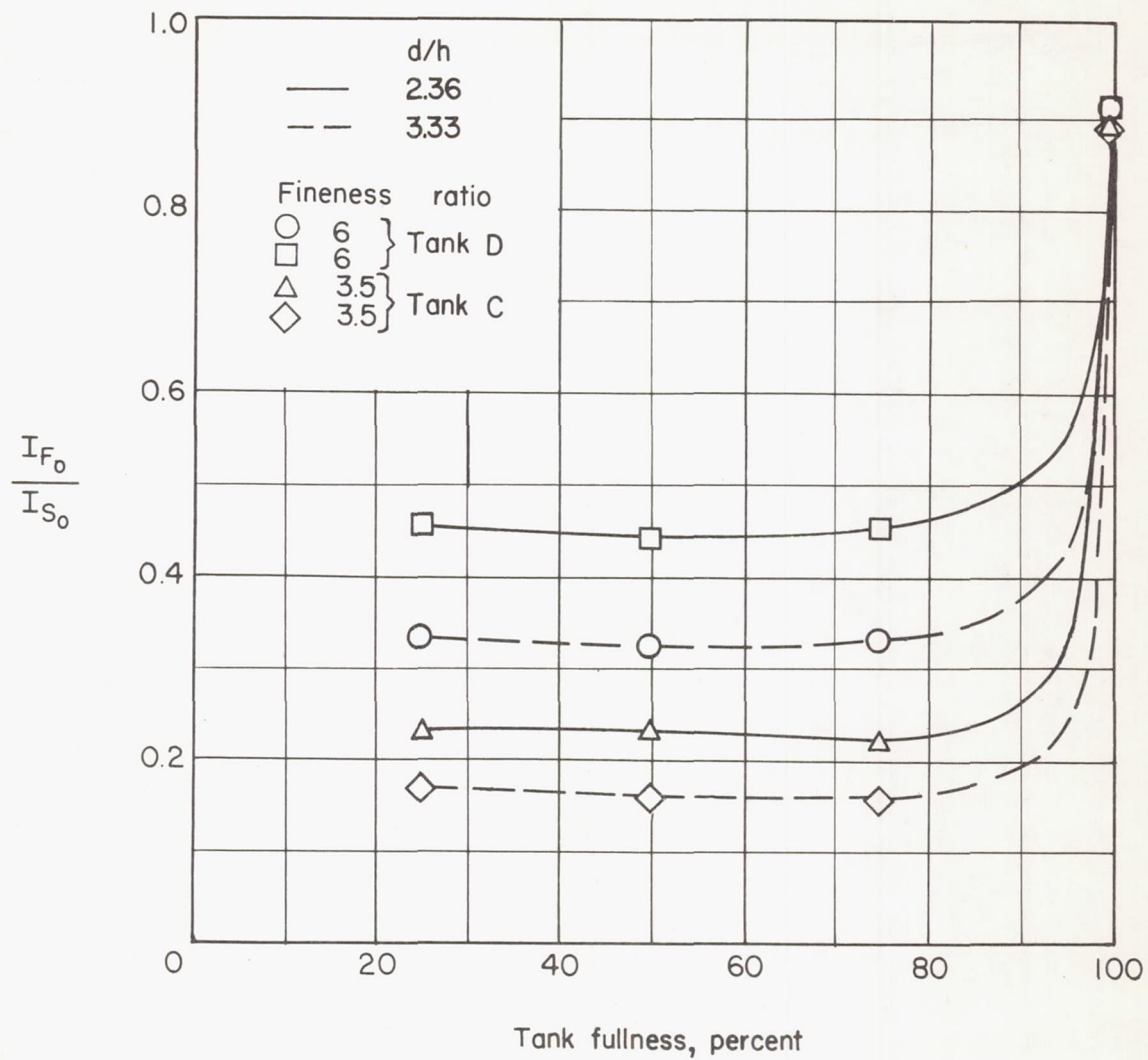

Figure 6.- Effect of pylon offset on inertia ratio for pylon-mounted tanks C and D.

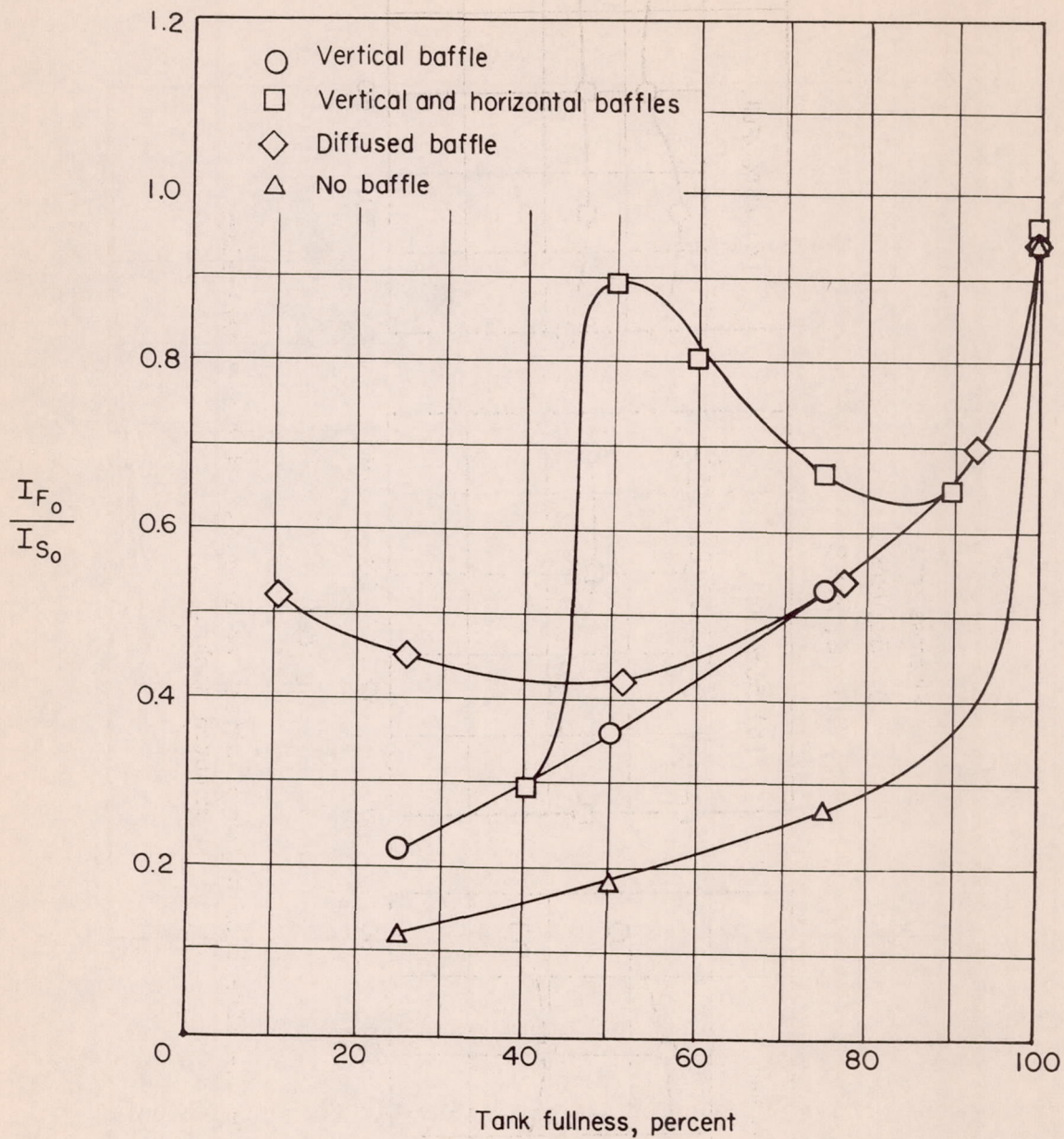

Figure 7.- Effect of baffles on inertia ratio for pylon-mounted tank E.  
 $d/h = 2.86$ .

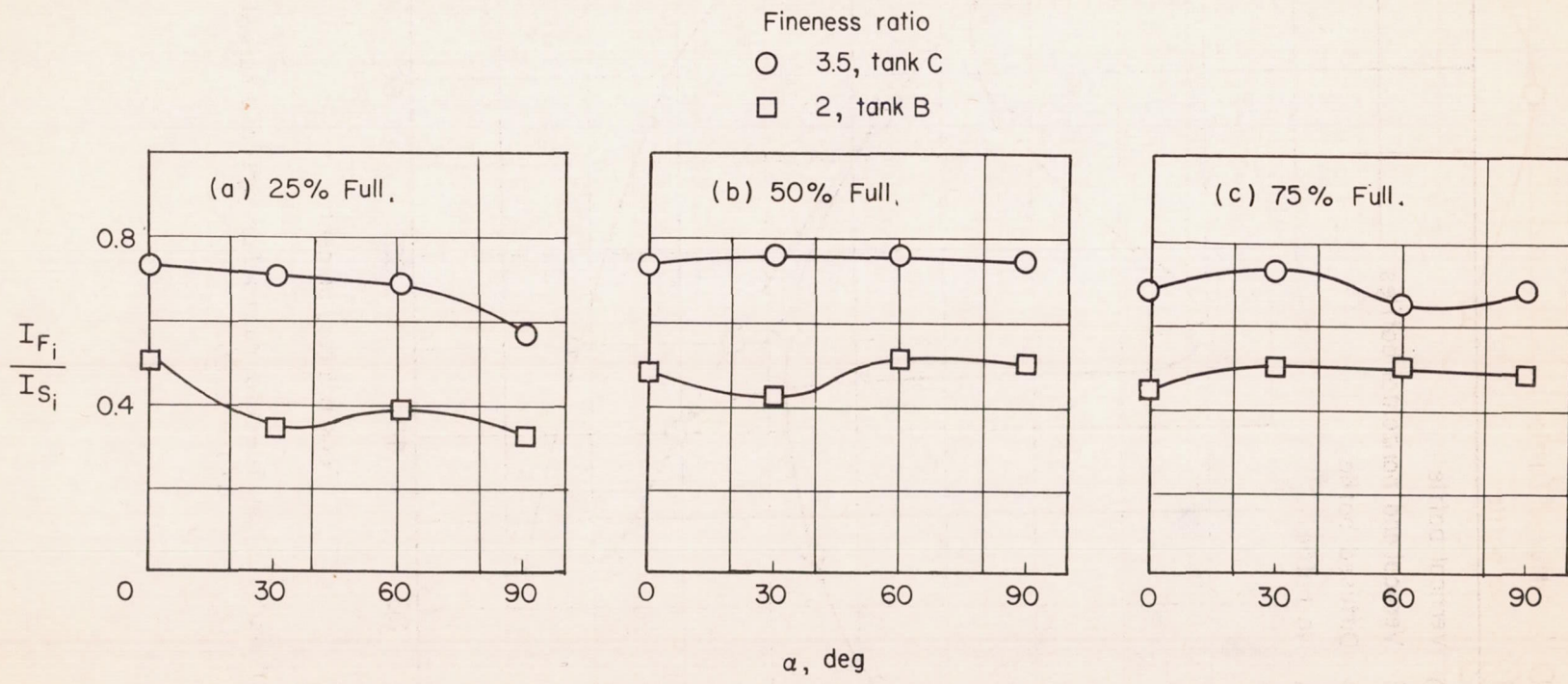

Figure 8.- Effect of angle of attack on inertia ratio for centrally mounted tanks.

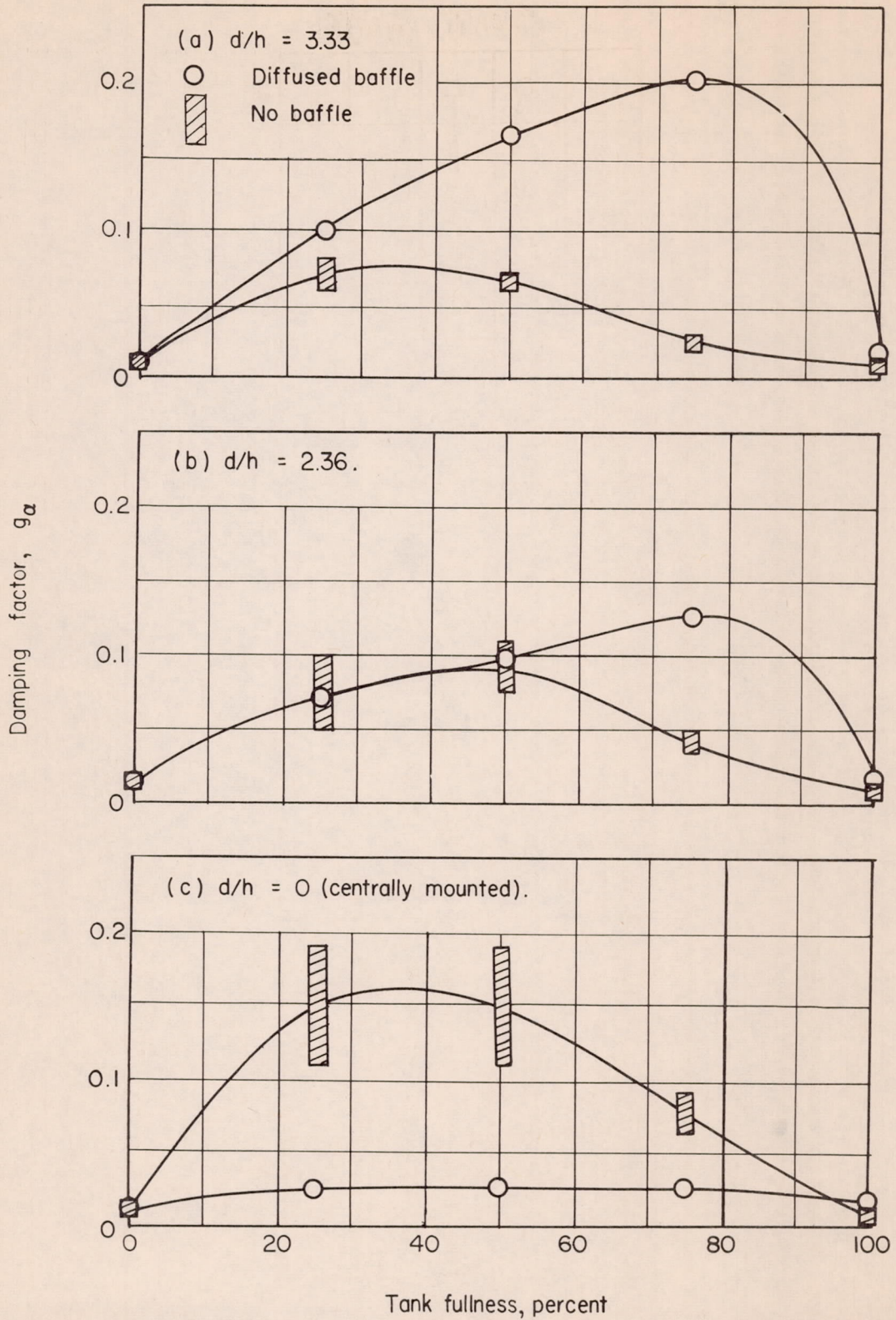

Figure 9.- Effect of diffused baffle on damping factor for tank G.